



INFRAPAK EZ-DUZ-IT PLUS



PACKAGING SOLUTIONS THAT MEAN BUSINESS

# INFRAPAK EZ-DUZ-IT PLUS®

SEMI-AUTOMATIC PLATFORM STRETCH WRAPPER

# INFRAPAK EZ-DUZ-IT PLUS®



The INFRAPAK EZ-DUZ-IT PLUS® is part of a robust line of stretch wrapping equipment designed to maximize stretch film usage while ensuring the very best load unitization. To guarantee years of reliable wrapping, all INFRAPAK equipment is constructed with heavy-duty reinforced structural steel, and finished with non-corrosive Steel-It paint.

The INFRAPAK EZ-DUZ-IT PLUS® is manufactured in the USA and serviced by our nationwide distributor network.



EZ-DUZ-IT PLUS® High Profile (HP)

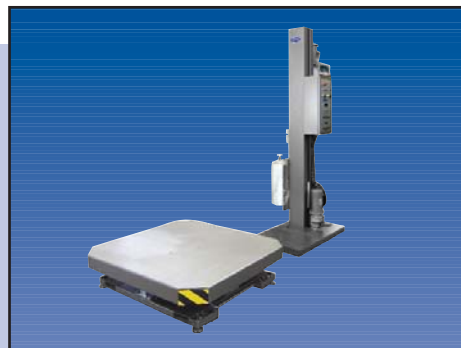

EZ-DUZ-IT PLUS® High Profile (HP) WRAP-N-WEIGH®

The INFRAPAK EZ-DUZ-IT PLUS® is a light duty wrapper offering semi-automatic operation at an economical price.

This 4,000 lb. capacity stretch wrapper is available with a high profile turntable for forklift loading, or low profile turntable for pallet-jack loading. A motorized film carriage with photoeye senses load heights.

The EZ-DUZ-IT PLUS® is often purchased with the WRAP-N-WEIGH® feature that combines wrapping and weighing into one operation by integrating a precision scale and digital controls on high or low profile turntables. Combining the two functions into one brings greater economy and efficiency to any wrapping operation requiring weighing.

The EZ-DUZ-IT PLUS® can be customized to suit your material handling requirements with extended towers for taller loads, extended bases for larger loads, and split frames for odd-sized larger loads. The standard EZ-DUZ-IT PLUS® comes completely assembled and ready to plug in.

## TURNTABLE OPTIONS

Variety of turntable sizes are available for applications where the full skid or slip sheet needs support

	Standard Turntable	Oversized
HP	50"W x 50"L square	60"W x 60"L square
LP	60" diameter	72" diameter

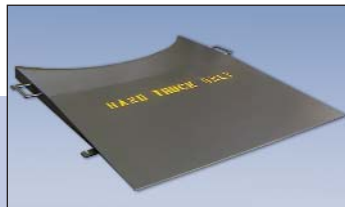

Variety of Access Ramps



Variable Carriage Speed, 0-12 FPM



WRAP-N-WEIGH® Operator Controls

## FEATURES

- Welded heavy-duty reinforced structural steel construction for around-the-clock operation
- Steel-It paint provides a durable scratch resistant surface and prevents corrosion
- Forklift portable
- 4 point caster support for HP turntable
- 6 pairs - Delrin caster support for LP turntable
- Turntable direct drive: 1/2 HP, 90 VDC motor with ANSI 50 chain
- Micro controller logic
- UL approved components
- External fuses
- NEMA 12 enclosure for dusty environments or where electrical codes are required
- Top over-wrap control feature (TOC)
- Cycle pause control
- Turntable jog control
- Carriage pause control (banding)
- Dual LED wrap counters
- Adjustable top and bottom wrap counters (0-9)
- Positive home position alignment
- Photo electric load height sensor that detects most dark colored loads
- Variable carriage speed (0-21 FPM)
- Carriage drive: 1/3 HP, 90 VDC motor with ANSI chain drive
- Variable stretch control (manual 0-100%)

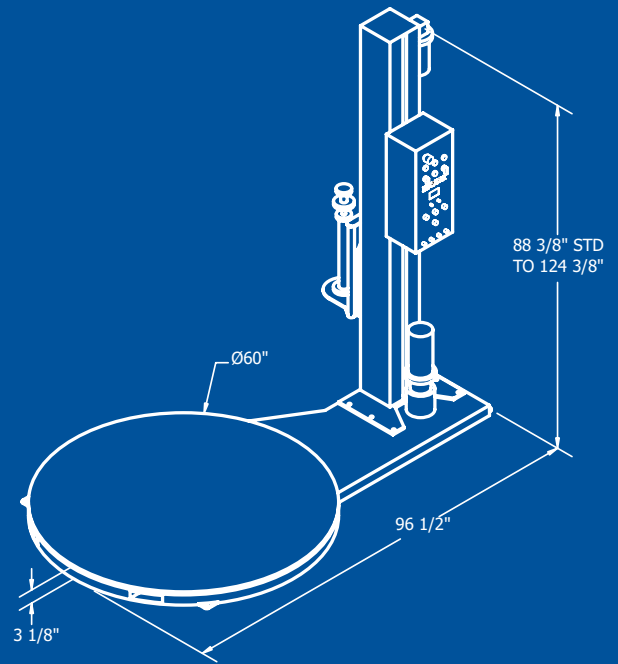
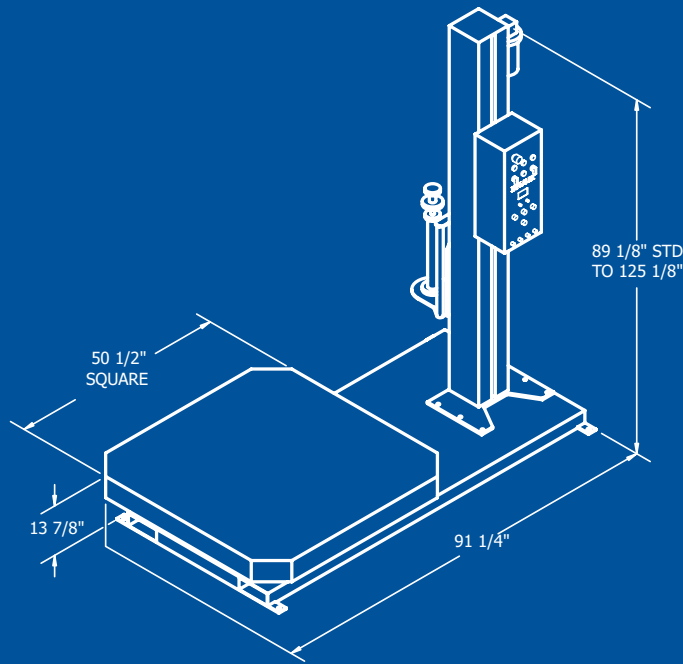

## SPECIFICATIONS

### Power Requirements

- Electrical: 120V, 1Ph, 60Hz, 10A

### Load Sizes

Frame	Load Height	Max. Load Diagonal Clearance
HP	74"	85"
LP	84"	85"
HP WNW	72"	85"
LP WNW	81"	85"

### Approx. Shipping Weight

- HP: 1,055 lbs.
- LP: 1,122 lbs.

## OPTIONS

- Extended base frames offer additional turning clearance for oversized pallets
- Extended film tower for wrapping taller loads exceeding standard machine capability
- TOP PLATEN device used to stabilize tall or light unstable loads for rotation
- A variety of access ramps to assist loading of pallets
- Split frame construction to increase film tower clearance for oversized loads
- Cycle counter to count the actual cycles of a machine operation
- Can be retrofitted to Powered Pre-Stretch
- More options available, consult your local INFRAPAK representative

For complete product line, visit: [www.arpac.com](http://www.arpac.com)

