



INFRAPAK PRO-SERIES



PACKAGING SOLUTIONS THAT MEAN BUSINESS

# INFRAPAK PRO-SERIES®

SEMI-AUTOMATIC PLATFORM STRETCH WRAPPER WITH POWERED PRE-STRETCH

# INFRAPAK PRO-SERIES®



The new INFRAPAK PRO-SERIES® enjoys the reputation of being one of the most cost-effective semi-automatic machines on the market today. A new ergonomic sturdy design, with chains enclosed in the tower frame, ensures safer operation. Standard features include: illuminated adjustable (0-9) LED top & bottom wrap counters, top overwrap control, anti-static film rollers, cycle pause, variable speed controls for both turntable and carriage, upgraded photo eye to see most dark loads, plus EZ-LOAD Powered Pre-Stretch, maximizing stretch film usage.

This 4,000 lb. capacity system is available with a high profile turntable for forklift loading, or low profile turntable for pallet-jack loading.

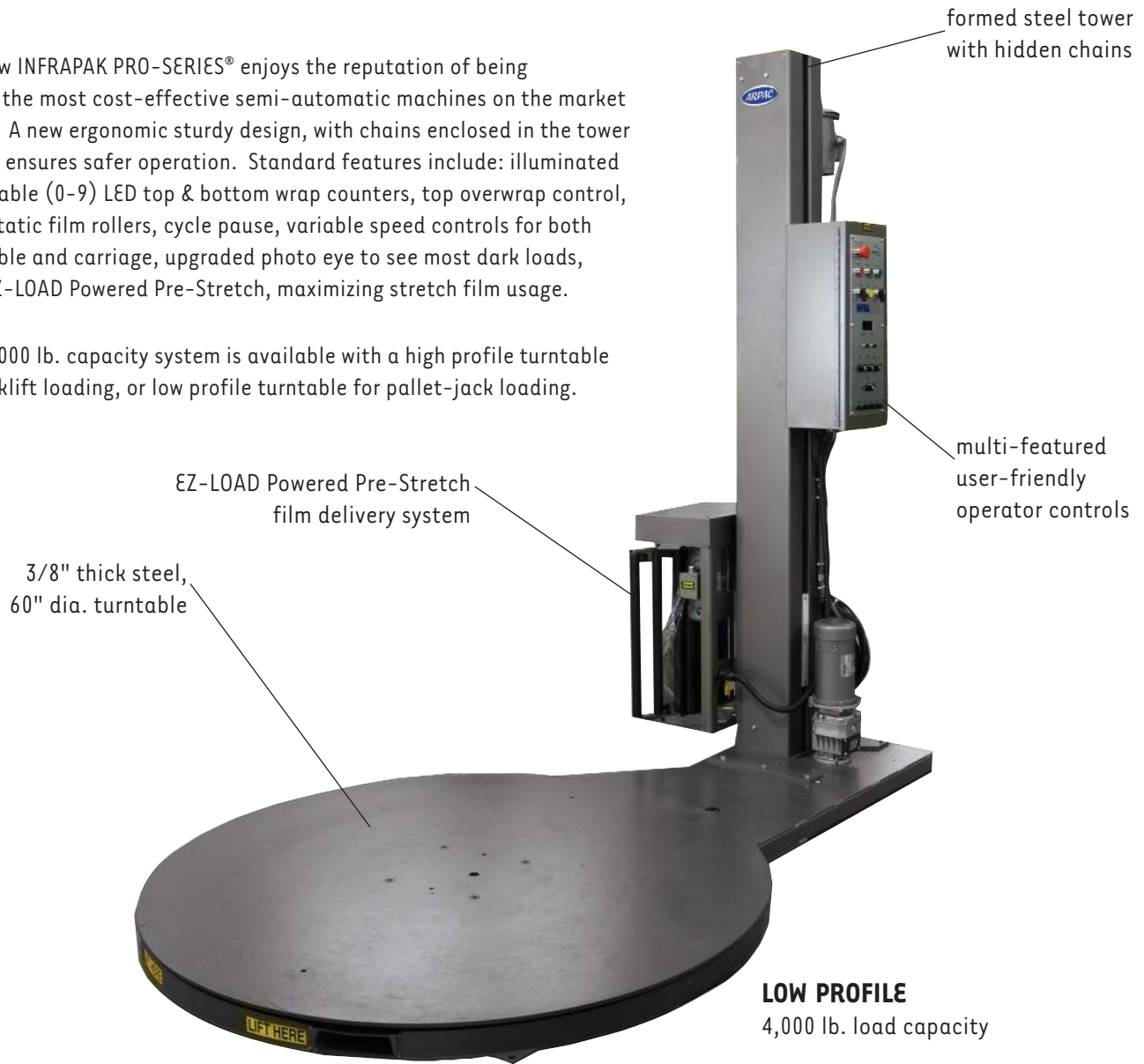

PRO-SERIES® High Profile (HP)

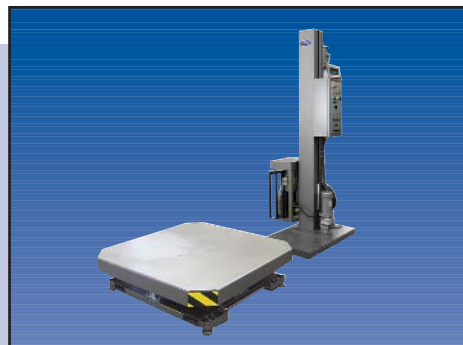

PRO-SERIES® High Profile (HP) WRAP-N-WEIGH®

The INFRAPAK PRO-SERIES® is often purchased with the WRAP-N-WEIGH® feature that combines wrapping and weighing operations. A precision scale and digital controls are integrated into the machine which brings greater economy and efficiency to any wrapping operation requiring weighing.

The INFRAPAK PRO-SERIES® can be customized to suit your material handling requirements with extended towers for taller loads and split frames for odd-sized larger loads.

The new INFRAPAK PRO-SERIES® is part of a robust line of stretch wrapping equipment designed to maximize stretch film usage while ensuring the very best load unitization. All INFRAPAK equipment is constructed with heavy-duty reinforced structural steel, and finished with non-corrosive Steel-It paint, to guarantee years of reliable wrapping. The INFRAPAK PRO-SERIES® is manufactured in the USA and serviced by our nationwide distributor network.

## TURNTABLE OPTIONS

Variety of turntable sizes are available for applications where the full skid or slip sheet needs support

	Standard Turntable	Oversized
HP	50"W x 50"L square	60"W x 60"L square
LP	60" diameter	72" diameter



"Swift Change" Film Mandrel

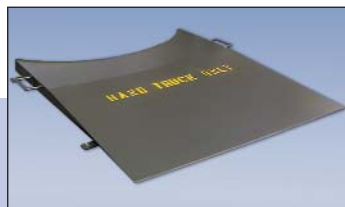

Variety of Access Ramps



EZ-LOAD Powered Pre-Stretch



WRAP-N-WEIGH® Operator Controls

## FEATURES

- Welded heavy-duty reinforced structural steel construction for around-the-clock operation
- Steel-It paint provides a durable scratch resistant surface and prevents corrosion
- Forklift portable
- 4 point caster support for HP turntable
- 6 pairs - Delrin caster support for LP turntable
- Turntable direct drive: 1/2 HP, 90 VDC motor with ANSI 50 chain
- Micro controller logic
- Top over-wrap control feature (TOC)
- Cycle pause control
- Turntable jog control
- Carriage pause control (banding)
- Adjustable dual LED wrap counters (0-9)
- Corner compensation
- Anti-static rollers
- UL approved components
- External fuses
- Positive home position alignment
- Photo electric load height sensor that detects most dark colored loads
- EZ-LOAD Powered Pre-Stretch 150-300%, 200% Standard
- Variable carriage speed (0-21 FPM)
- Carriage drive: 1/3 HP, 90 VDC motor with ANSI chain lift drive

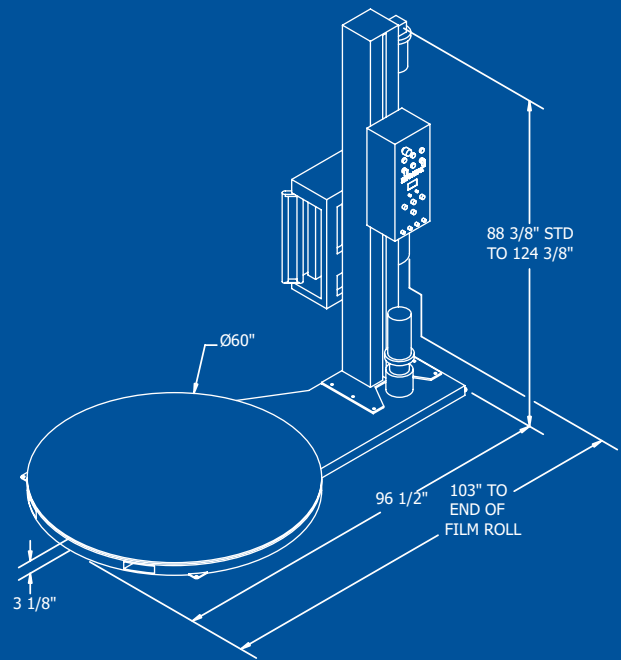
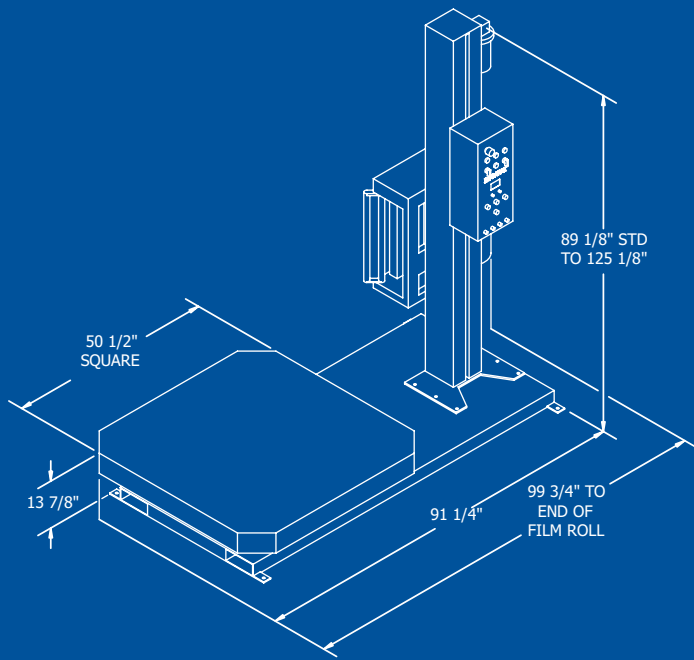

## SPECIFICATIONS

### Power Requirements

- Electrical: 120V, 1Ph, 60Hz, 10A

### Load Sizes

Frame	Load Height	Max. Load Diagonal Clearance
HP	74"	85"
LP	83"	85"
HP WNW	72"	85"
LP WNW	81"	85"

### Approx. Shipping Weight

- HP: 1,386 lbs.
- LP: 1,485 lbs.
- HP WNW: 1,475 lbs.
- LP WNW: 1,568 lbs.

## OPTIONS

- Extended film tower for wrapping taller loads exceeding standard machine capability
- TOP PLATEN device used to stabilize tall or light unstable loads during rotation
- A variety of access ramps to assist loading of pallet
- Split frame construction to increase film tower clearance for oversized loads
- Cycle counter to count the actual cycles of a machine operation
- More options available, consult your local INFRAPAK representative

For complete product line, visit: [www.arpac.com](http://www.arpac.com)

