

SIDEWINDER 4-SERIES



PACKAGING SOLUTIONS THAT MEAN BUSINESS



INFRAPAK SIDEWINDER® 4-SERIES

SEMI-AUTOMATIC STRETCH WRAPPER

SIDEWINDER® 4-SERIES



The SIDEWINDER® 4 is part of a robust line of stretch wrapping equipment designed to maximize stretch film usage while ensuring the very best load unitization. All INFRAPAK equipment is constructed with heavy gauge reinforced structural steel and finished with non-corrosive Steel-It paint, guaranteeing years of reliable wrapping. The SIDEWINDER® 4 is manufactured in the USA and serviced by our nationwide distribution network.

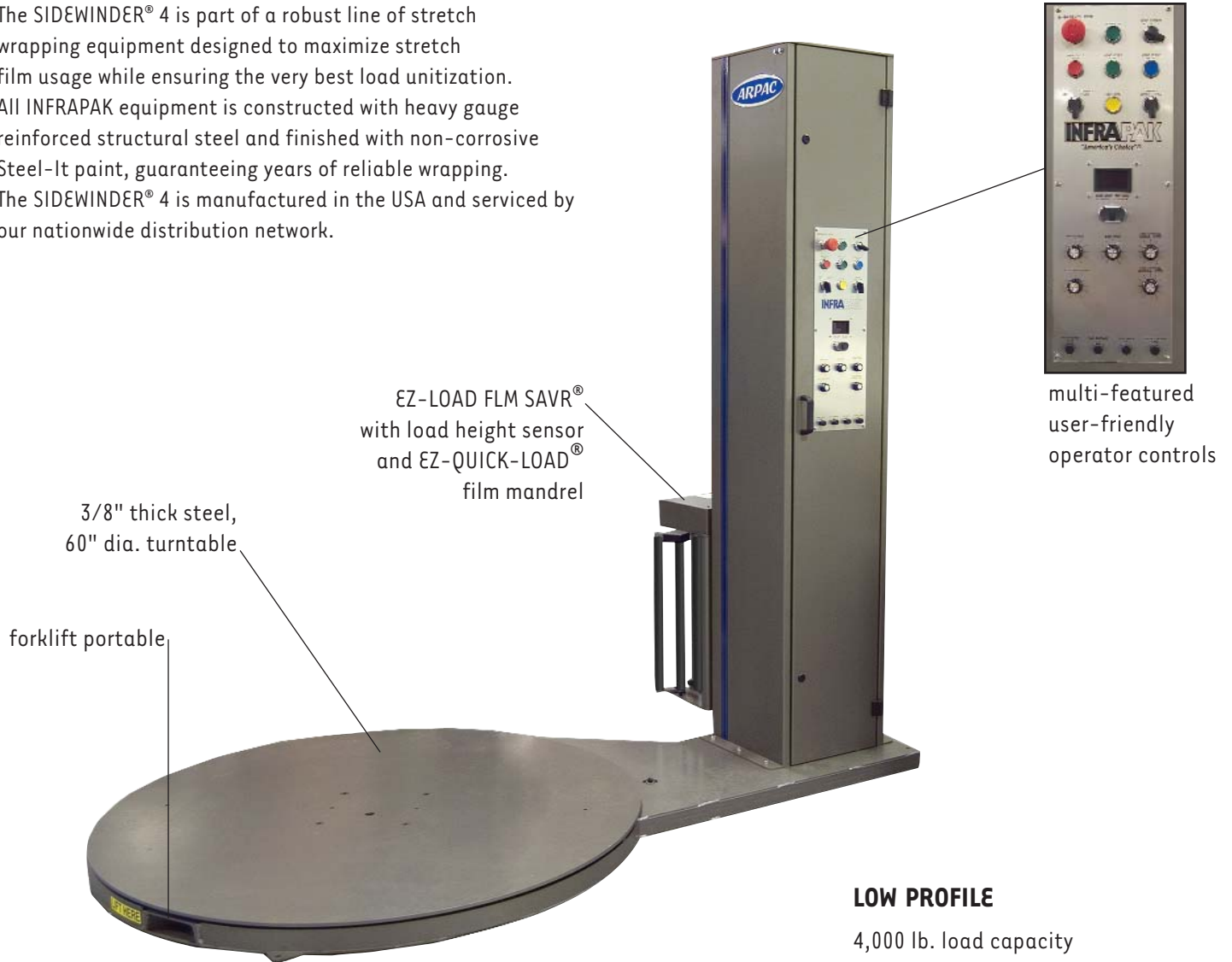

SIDEWINDER® 4 High Profile (HP)

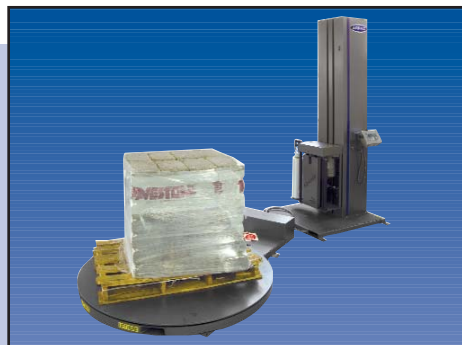

SIDEWINDER® 4 Low Profile (LP) Wrap-N-Weigh®



Dual Turntable Option (HP Shown)

The SIDEWINDER® 4 is a heavy-duty semi-automatic stretch wrapper with 4,000 lb. capacity. This model is available with a high profile turntable for forklift loading, and low profile turntable for pallet-jack loading.

The SIDEWINDER® 4 can be customized with extended towers for taller loads, and split frames for odd-sized larger loads. This system is also available with a 30" film carriage and dual turntables for greater throughput, cold and freezer packs for reliable operation in extremely harsh temperatures, and a pneumatic roping device for additional load support. For more efficiency, an Automatic Film Tear Device (AFTD) tears the film automatically at the end of the wrapping cycle.

- Robust ergonomic design
- Maintenance free
- User-friendly
- Replaces expensive handwrapping

TURNTABLE OPTIONS

Variety of turntable sizes available for applications where the full skid or slip sheet needs support.

| | Standard Turntable | Oversized | Oversized with Base Extension |
|----|--------------------|--------------------|-------------------------------|
| HP | 50"W x 50"L square | 60"W x 60"L square | NA |
| LP | 60" diameter | NA | 72" diameter 90" diameter |

Other sizes available. Consult factory for more information



EZ-LOAD FLM SAVR® Powered Pre-Stretch with Standard EZ-QUICK-LOAD® Film Mandrel

FEATURES

- Welded heavy-duty reinforced structural steel construction for around-the-clock operation
- Steel-It paint provides a durable scratch resistant surface and prevents corrosion
- 4 point caster support for HP turntable
- 6 pairs - Delrin caster support for LP turntable
- Turntable direct drive: 1/2 HP, DC motor with ANSI 50 chain
- Allen-Bradley® Micrologix PLC
- User-friendly operator controls with dual LED wrap counters
- Built in self-diagnostics
- Electronically controlled film tension adjustment
- Top over-wrap control feature
- Cycle pause and turntable jog control
- Carriage pause control (banding)
- Positive home position alignment
- 3 wrap pattern selections
- Photo electric load height sensor that detects most dark colored loads
- Adjustable top and bottom wrap counters (0-7)
- Corner compensation
- Anti-static rollers
- UL approved components
- External fuses
- Variable carriage speed (0-21 FPM)
- EZ-LOAD FLM SAVR® Powered Pre-Stretch 150%-300% (200% standard)
- Film delivery: 1/2 HP, 90 VDC motor
- Carriage drive: 1/3 HP, 90 VDC motor
- Dual ANSI chain lift drive

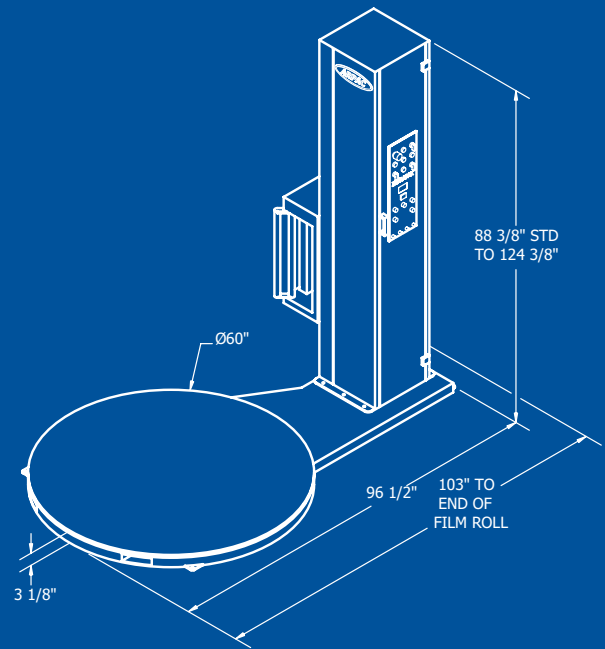
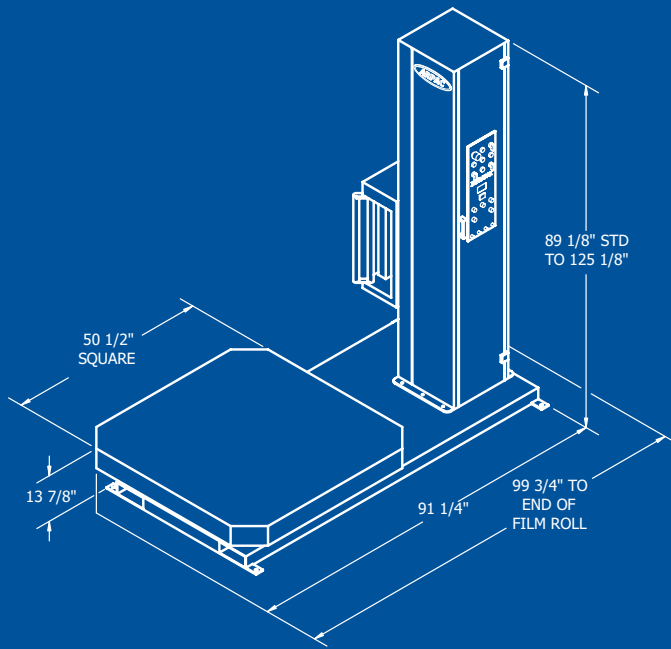

SPECIFICATIONS

Power Requirements

- Electrical: 120V, 1Ph, 60Hz, 10A

Load Size

| Frame | Load Height | Max. Load Diagonal Clearance |
|-------|-------------|------------------------------|
| HP | 74" | 85" |
| LP | 83" | 85" |

Approx. Shipping Weight

- HP: 1,380 lbs.
- LP: 1,400 lbs.

OPTIONS

- A variety of access ramps to assist loading of pallet
- Extended film towers for wrapping taller loads
- TOP PLATEN device for stabilizing tall, light or unstable loads during rotation
- Brake roller carriage
- Cold packs and freezer packs for cold temperatures
- AFTD (Automatic Film Tear Device)
 - automatically tears the film at the end of the cycle
- Pneumatic roping device for extra support of load (air required)
- Adjustable manual roping guide
- NEMA 12 enclosure for dusty environments
- More options available, consult your local INFRAPAK representative

