



SIDEWINDER 6-SERIES



PACKAGING SOLUTIONS THAT MEAN BUSINESS

INFRAPAK SIDEWINDER® 6-SERIES

SEMI-AUTOMATIC PLATFORM STRETCH WRAPPING SYSTEMS

SIDEWINDER® 6-SERIES



The SIDEWINDER® 6 is part of a robust line of stretch wrapping equipment designed to maximize stretch film usage while ensuring the very best load unitization. All INFRAPAK equipment is constructed with heavy-duty reinforced structural steel finished with Steel-It paint to guarantee years of reliable wrapping. The SIDEWINDER® 6 is manufactured in the USA and serviced by our nationwide distributor network.

3/8" thick steel
72" dia. turntable

forklift portable

EZ-LOAD FLM SAVR®
with load height sensor
and EZ-QUICK-LOAD®
film mandrel



multi-featured
user-friendly
operator controls

LOW PROFILE

6,000 lb. load capacity



SIDEWINDER® 6 High Profile (HP)

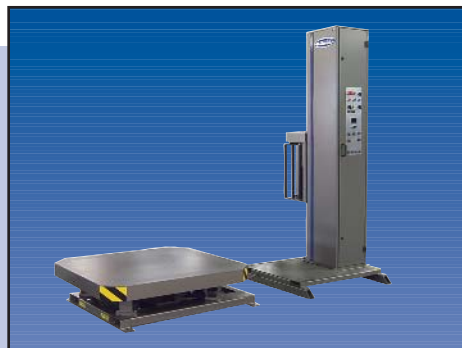

SIDEWINDER® 6 Split Frame Option



Top Platen Option (HP Shown)

The SIDEWINDER® 6 is a heavy-duty semi-automatic stretch wrapper with 6,000 lb. capacity. This model is available with a high profile turntable for forklift loading, and low profile turntable for pallet-jack loading.

The operator attaches the film to the load, and presses the start button to begin the wrap sequence. After the load is wrapped, the operator cuts the film. An optional Automatic Film Tear Device (AFTD) tears the film automatically at the end of the wrapping cycle.

The SIDEWINDER® 6 can be customized to suit your material handling requirements with extended towers for taller loads, extended bases for larger loads, and split frames for odd-sized larger loads.

The SIDEWINDER® 6 is also available with a 30" film carriage and dual turntables for greater throughput, cold and freezer packs for reliable operation in extremely harsh temperatures, and a pneumatic roping device for extra load support.

TURNTABLE OPTIONS

Variety of turntable sizes available for applications where the full skid or slip sheet needs support.

	Standard Turntable	Oversized
HP	50"W x 50"L square	60"W x 60"L square
LP	72" diameter	90" diameter



EZ-LOAD FLM SAVR® Powered Pre-Stretch with Standard EZ-QUICK-LOAD® Film Mandrel

FEATURES

- Welded heavy-duty reinforced structural steel construction for around-the-clock operation
- Steel-It paint provides a durable scratch resistant surface and prevents corrosion
- Forklift portable
- 4 point caster support for HP turntable
- 8 pairs - Delrin caster support for LP turntable
- Turntable direct drive: 3/4 HP, DC motor with ANSI 60 chains
- Allen-Bradley® Micrologix PLC
- User-friendly operator controls with dual LED wrap counters
- Built in self-diagnostics
- Electronically controlled film tension adjustment
- Top over-wrap control feature
- Cycle pause and turntable jog control
- Carriage pause control (banding)
- Positive home position alignment
- 3 wrap pattern selections
- Photo electric load height sensor that detects most dark colored loads
- Adjustable top and bottom wrap counters (0-7)
- Corner compensation
- Anti-static rollers
- UL approved components
- External fuses
- Variable carriage speed (0-21 FPM)
- EZ-Load FLM SAVR: Powered Pre-stretch 150%-300% (200% standard)
- Film delivery: 1/2 HP, 90 VDC motor
- Carriage drive: 1/3 HP, 90 VDC motor
- Dual ANSI chain lift drive

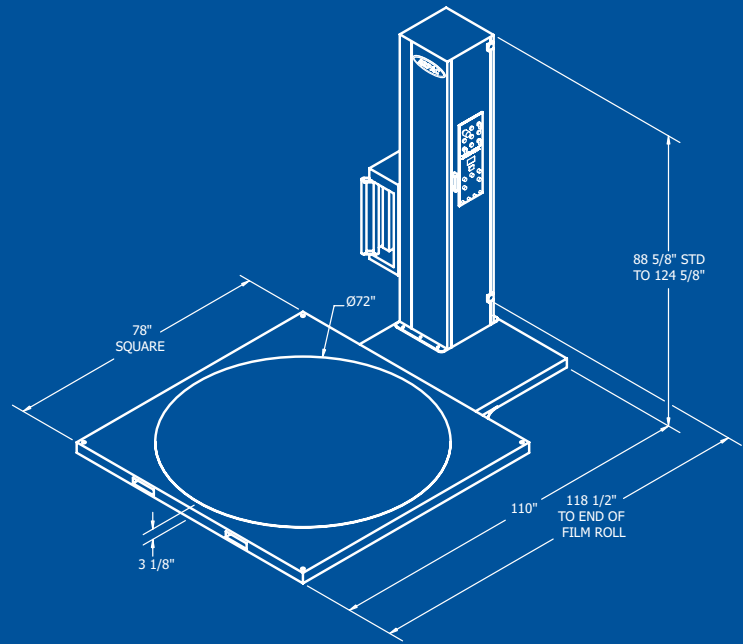
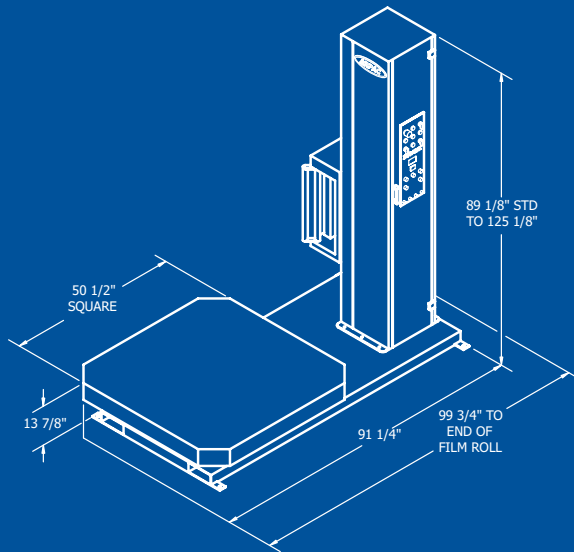

SPECIFICATIONS

Power Requirements

- Electrical: 120V, 1Ph, 60Hz, 15A

Load Size

Frame	Load Height	Max. Load Diagonal Clearance
HP	74"	85"
LP	83"	85"

Approx. Shipping Weight

- HP: 2,500 lbs.
- LP: 4,000 lbs.

OPTIONS

- A variety of access ramps to assist loading of pallet
- Extended base frames for additional turning clearance of oversized pallets
- Extended tower and turntable upgrades
- TOP PLATEN device for stabilizing tall, light, or unstable loads during rotation
- Brake roller carriage to run netting medium
- Cold packs and freezer packs for cold temperatures
- AFTD (Automatic Film Tear Device)
 - automatically tears the film at the end of the cycle
- Pneumatic roping device for extra load support (air required)
- Adjustable manual roping guide
- NEMA 12 enclosure for dusty environments
- Can be manufactured for washdown environments
- Built-in Wrap-N-Weigh base
- Split base
- More options available, consult your local INFRAPAK sales representative

